

Special-Sensors for Automation



Infrared Detectors

- Measuring range 50...2000 °C
- Analog and switching output
- Fibre-optic up to 350 °C
- For heavy industry - IP 68



www.ege.nt-rt.ru

**ISO 9001
certified**

Архангельск (8182)63-90-72	Калининград (4012)72-03-81	Нижний Новгород (831)429-08-12	Смоленск (4812)29-41-54
Астана +7(7172)727-132	Калуга (4842)92-23-67	Новокузнецк (3843)20-46-81	Сочи (862)225-72-31
Белгород (4722)40-23-64	Кемерово (3842)65-04-62	Новосибирск (383)227-86-73	Ставрополь (8652)20-65-13
Брянск (4832)59-03-52	Киров (8332)68-02-04	Орел (4862)44-53-42	Тверь (4822)63-31-35
Владивосток (423)249-28-31	Краснодар (861)203-40-90	Оренбург (3532)37-68-04	Томск (3822)98-41-53
Волгоград (844)278-03-48	Красноярск (391)204-63-61	Пенза (8412)22-31-16	Тула (4872)74-02-29
Вологда (8172)26-41-59	Курск (4712)77-13-04	Пермь (342)205-81-47	Тюмень (3452)66-21-18
Воронеж (473)204-51-73	Липецк (4742)52-20-81	Ростов-на-Дону (863)308-18-15	Ульяновск (8422)24-23-59
Екатеринбург (343)384-55-89	Магнитогорск (3519)55-03-13	Рязань (4912)46-61-64	Уфа (347)229-48-12
Иваново (4932)77-34-06	Москва (495)268-04-70	Самара (846)206-03-16	Челябинск (351)202-03-61
Ижевск (3412)26-03-58	Мурманск (8152)59-64-93	Санкт-Петербург (812)309-46-40	Череповец (8202)49-02-64
Казань (843)206-01-48	Набережные Челны (8552)20-53-41	Саратов (845)249-38-78	Ярославль (4852)69-52-93

Function and application

Where conventional sensors would fail due to too high temperature, infrared detectors working on a non-contact principle can be used. They respond to the radiated heat of the hot materials. Compact units with optics are used for distances of 2 to 8 m from the object. For distances of only a few cm, heat-resistant light-conducting cables should be used for transmission.

Series ODM

Infrared detectors ODM... detect energy radiated by a hot body in the near infrared range (1...3 μm). Energy absorbed within the spectral range determines detected temperatures. Optical and assessment electronics are situated in a stainless steel casing. O-ring gaskets ensure safe operation even in the presence of large temperature and humidity fluctuations. The plug connector is water tight to IP 68.

If environmental temperatures exceed 70° C, an optical fibre cable can be used up to 250° C. This can be fitted with a supplementary optical system if required. In case of such applications, the optical fibre cable should be laid in protective tubes and not be frequently moved.

The fibre cable fast-connector LLK-plug allows for fast and safe exchange.

The infrared detectors are specified for different sensitivities. If the target temperature exceeds the sensitivity specified, the output of the detector will be activated.

Series OD 100

The sensor OD 100 GSPP detects temperatures up to 300°C contactlessly. Within this temperature range it is possible to adjust two switching points. The switching status is indicated by two colour LEDs.

The sensor OD 100 GA has one analog output 4...20 mA. The temperature of an object detected by the infrared detector depends on the emission coefficient, the distance and the lighting area. To prevent these influences it is important to adjust the switching points of the infrared-detector on site.

Series ODE

The ODE 350 infrared sensor measures the energy transmitted from a body in the near infrared region (1...3 μm). The energy taken up in this region of the spectrum is a measure of the temperature of the hot object. The device has four outputs which are independent of one another; two analogue outputs (current, voltage) and two outputs each with a switching threshold preselectable as either a relay change-over contact or as a semiconductor output. The required characteristic curve is preselected by a selector switch.

The device is operated using a fibre-optic cable, which can have temperature stability of up to 350 °C. The standard cable can take up to 250 °C. They have quick-release fastener provided with thread. To limit the angular field and increase sensitivity supplementary lenses for fibre-optic cable are available.

The given sensitivities refer to the use of a 1m long fibre-optic cable with a bundle diameter of 4 mm during full illumination. Other fibre-optic cables and lenses yield correspondingly different minimum operating temperatures. As a rule, a fibre-optic cable with an additional length of 1 m decreases the reaction sensitivity by 75 °C.

Adjustment on switching detectors

1. Remove protection screw from the potentiometer.
2. The sensor must be mounted at its finally position.
3. Turn the screwdriver till the output switches (LED red).
Now the temperature is adjusted on which the infrared-detector responded. The switching temperature can be increased if you turn the potentiometer clockwise.
4. Remount the protection screw.

Analog temperature detection

The current output for the temperature is correct when:

- A) the measured object has a homogeneous temperature and when its area has a minimum size of the sensor's detection range (see path of the rays)
- B) the emission coefficient is $\epsilon = 1$ (black body).

At other cases the OD 100 GA measure a too low temperature. Therefore the OD 100 GA has a potentiometer for an adjustment.

Adjustment

1. Remove protection screw from the potentiometer.
2. The sensor must be mounted at is final position.
3. The actual temperature of the object must be known.
4. Turn the potentiometer clockwise until the output current correspond with the object temperature (see output characteristics).

Typical diagrams for infrared detectors

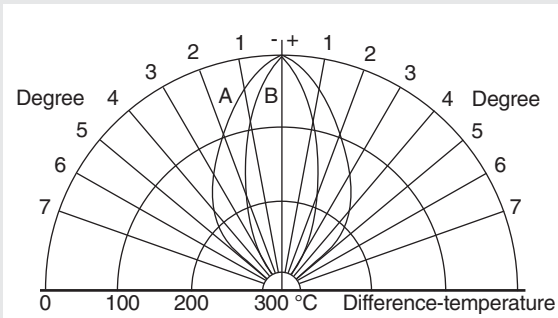

Diagram 1

A: 5°-Optics; B: 2°-Optics

In most applications the pre-set threshold temperature of probes with predetermined threshold levels and the temperature of the hot surface (of the medium) are not exactly the same. Rather, the threshold temperature of the infrared sensor is always set lower than it would need to be for the detection of the hot surface.

This makes sense for the reason that temperature oscillations or oscillating emissions from the metal surface often occur which would cause the infrared detector to trigger when it was not wanted. Experience shows that the threshold temperature of the infrared detector should therefore be chosen 50 - 100 degrees Celsius lower than is required. In other applications, materials must be detected which span a large temperature range (300 - 600°C). Then the lowest occurring temperature must still be detectable, which implies that the threshold temperature of the infrared detector must be chosen to be very low. Therefore, there is always a difference between the medium temperature and the threshold temperature of the infrared detector. This is the differential temperature.

The connection between differential temperature and the achieved angular field is represented in diagram 1.

In order to determine the actual angular field, one selects the circle with the desired or estimated differential temperature and looks for the intersection points with the radiation diagrams of the A or B optics. Once one has found these intersection points, one must only read off which angular radius runs through these points.

Example: Differential temperature 100 degrees, 2° optics (B), the intersection point of the differential temperature circle and the radiation diagram is at angular radius of ± 1.2 degrees. The actually achieved angular field is therefore 2.4 degrees.

Due to the characteristics of the photovoltaic cells used in the infrared detector and the infrared optics, the actually achieved angular field is not constant, but is dependent on the temperature of the medium. This effect is comparable to the overexposure of a photograph.

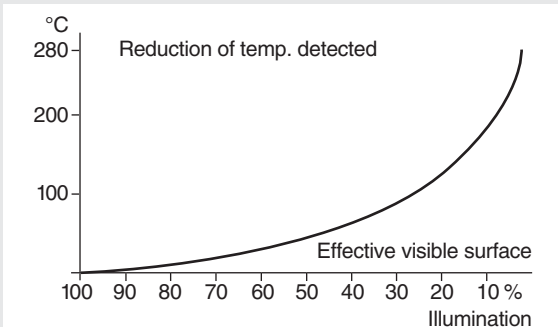

Diagram 2

If the hot surface is smaller than the field of view of the infrared detector, not so much energy enters into the opening of the infrared detector as would be possible under full illumination. Therefore the temperature will be falsely determined. This can be corrected when it is known what percentage of the field of view is covered by the hot surface.

If the illumination is not 100%, the threshold temperature of the infrared detector must be lowered in order to detect the hot surface. (Diagram 2)

$$\text{Illumination(\%)} = \frac{\text{object surface area}}{\text{detector visible surface}}$$

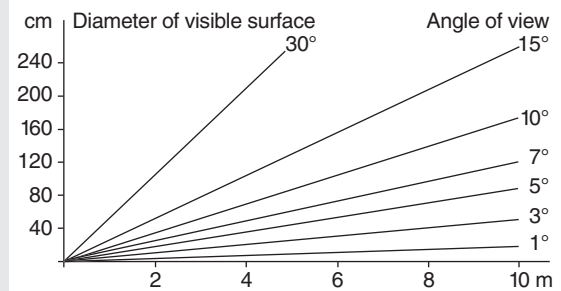

Diagram 3

For infrared detectors with spherical optics, the field of view is always circular. For specific optics (50, 100 mm focal length) there is a constant angular field (φ). At a predetermined distance (A), the infrared detector "sees" a circular area that is called the visible surface (B). If the hot surface is as large as the field of view or even larger, the illumination is 100% (Diagram 3).

$$B = 2 \times A \times \tan \frac{\varphi}{2}$$

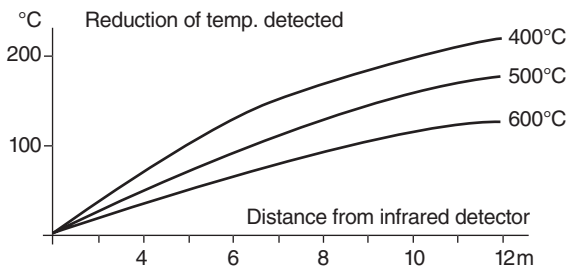

Diagram 4

The energy emitted by a hot surface at temperature T is distributed throughout the entire surrounding space. The further the infrared detector is from the hot surface, the less the energy is that can enter into the optics of the infrared detector. Since the temperature measurement in the infrared detector succeeds through conversion of energy into temperature, the infrared detector measures an increasingly smaller temperature the further away it is removed from the hot surface. The larger the separation therefore, the more the threshold temperature of the infrared detector must be lowered.

It is assumed in diagram 4 that the field of view of the infrared detector is always fully illuminated.

Compact models

Series ODMO

Sensors with switching output

Threshold 300 - 600 - 750 °C

Field of view 2°

Modular system

Waterproof IP 68 + IP 69K



Design	DC PNP • 2 conductor AC • 2 Grad-Optics						
Dimensions							
Sensing temperature [°C]	300	300	600	600	750	750	
Output							
ID-No.	P60051	P60052	P60057	P60058	P60063	P60064	
Type	ODMO 402 WS	ODMO 402 GSP	ODMO 602 WS	ODMO 602 GSP	ODMO 902 WS	ODMO 902 GSP	
Operating voltage [V]	20...250 AC	10...55 DC	20...250 AC	10...55 DC	20...250 AC	10...55 DC	
Switching current [mA]	400	400	400	400	400	400	
Short circuit proof	-	•	-	•	-	•	
Overcurrent release [mA]	-	450	-	450	-	450	
Voltage drop max. [V]	7	2	7	2	7	2	
Minimum load current [mA]	20	-	20	-	20	-	
Current consumption [mA]	3	15	3	15	3	15	
Hysteresis	approx. 5% of the sensing temperature						
Ambient temperature [°C]	-20...+75						
EMC-class	A						
Protection [EN 60529]	IP 68 + IP 69K						
Housing material	AISI 316 Ti						
Connection	VEG 5-5, IP 68						
Connection VEG 5-5							
View to plug side							
Accessories	see page 6.10						

Compact models

Series ODMO

Sensors with switching output

Threshold 300 - 600 - 750 °C

Field of view 5°
Modular system

Waterproof IP 68 + IP 69K



Design DC PNP • 2 conductor AC • 5 Grad-Optics

Dimensions

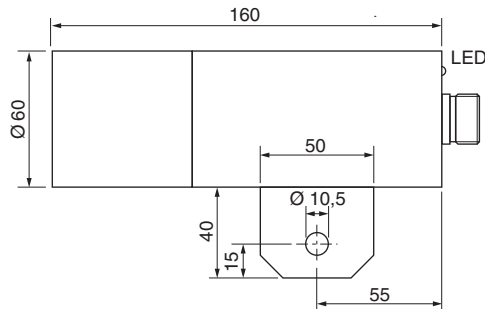

Sensing temperature [°C]	300	300	600	600	750	750
Output						
ID-No.	P60054	P60055	P60060	P60061	P60066	P60067
Type	ODMO 405 WS	ODMO 405 GSP	ODMO 605 WS	ODMO 605 GSP	ODMO 905 WS	ODMO 905 GSP
Operating voltage [V]	20...250 AC	10...55 DC	20...250 AC	10...55 DC	20...250 AC	10...55 DC
Switching current [mA]	400	400	400	400	400	400
Short circuit proof	-	•	-	•	-	•
Overcurrent release [mA]	-	450	-	450	-	450
Voltage drop max. [V]	7	2	7	2	7	2
Minimum load current [mA]	20	-	20	-	20	-
Current consumption [mA]	3	15	3	15	3	15
Hysteresis	approx. 5% of the sensing temperature					
Ambient temperature [°C]	-20...+75					
EMC-class	A					
Protection [EN 60529]	IP 68 + IP 69K					
Housing material	AISI 316 Ti					
Connection	VEG 5-5, IP 68					

Connection VEG 5-5

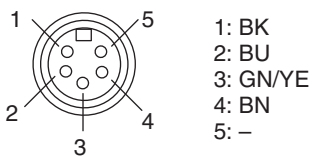

View to plug side

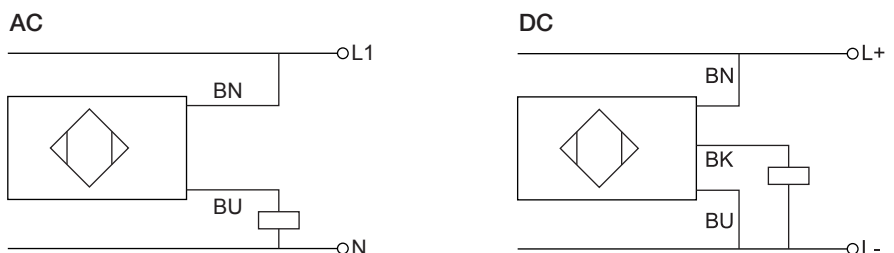

Accessories see page 6.10

Fibre glass optic

Series ODML

Sensors with switching output

Threshold 350 - 650 - 800 °C

Field of view 4° und 8°
Modular system

Special plug for IP 68

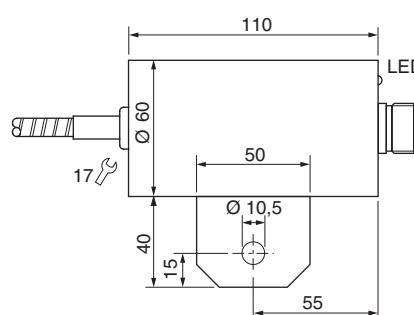
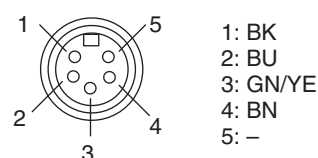
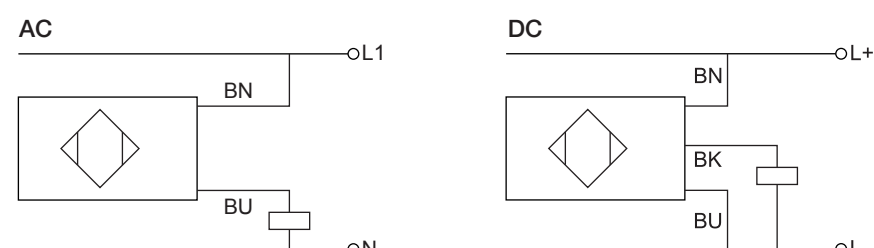

Design	DC PNP • 2 conductor AC • Amplifier for fibre optics					
Dimensions						
Sensing temperature [°C]	350	350	650	650	800	800
Output						
ID-No.	P60068	P60069	P60071	P60072	P60074	P60075
Type	ODML 400 WS	ODML 400 GSP	ODML 600 WS	ODML 600 GSP	ODML 900 WS	ODML 900 GSP
Operating voltage [V]	20...250 AC	10...55 DC	20...250 AC	10...55 DC	20...250 AC	10...55 DC
Switching current [mA]	400	400	400	400	400	400
Short circuit proof	-	•	-	•	-	•
Overcurrent release [mA]	-	450	-	450	-	450
Voltage drop max. [V]	7	2	7	2	7	2
Minimum load current [mA]	20	-	20	-	20	-
Current consumption [mA]	3	15	3	15	3	15
Hysteresis	approx. 5% of the sensing temperature					
Ambient temperature [°C]	-20...+75					
EMC-class	A					
Protection [EN 60529]	IP 67					
Housing material	AISI 316 Ti					
Connection	VEG 5-5, IP 68					
Connection VEG 5-5						
View to plug side						
Accessories	see page 6.10					

Compact models

Series OD 100

Sensor with two switching points

Measuring-range 0...300 °C

Two switching outputs PNP

Stainless steel housing



Design DC PNP • M38x1.5

Dimensions

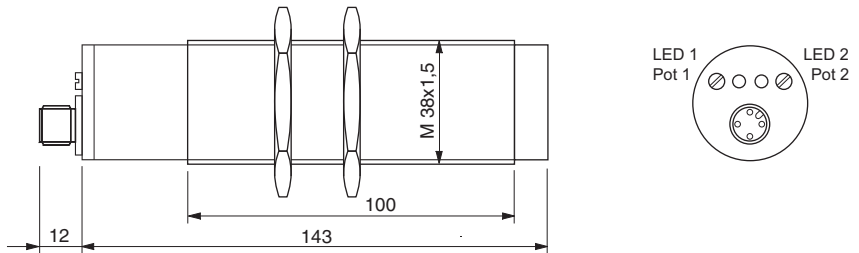

Sensing range [°C]	0...300
Output	
ID-No.	P61003
Type	OD 100 GSPP
Operating voltage [V]	18...32 DC
Current consumption [mA]	<20
Switching current [mA]	400
Overcurrent release [mA]	450
Voltage drop max. [V]	2
Field of view [°]	<10
Reproduction [°C]	±1
Temperature coefficient [%/K]	±1 of the measuring value
Hysteresis [°C]	5
Response time [ms]	100
Ambient temperature [°C]	-10...+60
EMC-class	A
Protection [EN 60529]	IP 67
Housing material	AISI 316 Ti
Connection	M12 connector

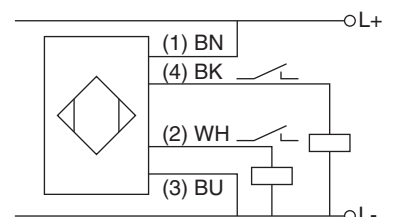
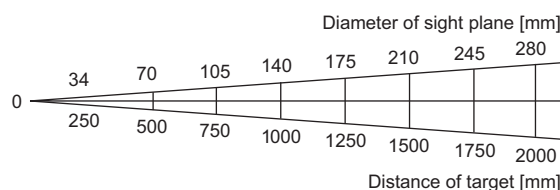
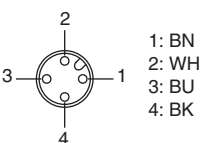

Accessories see page 6.10

Analog detector

Series OD 100

Analog infrared detectors

Measuring-range 0...300 °C

Analog output 4...20 mA

Stainless steel housing



Design

DC 4...20 mA • M38x1.5

Dimensions

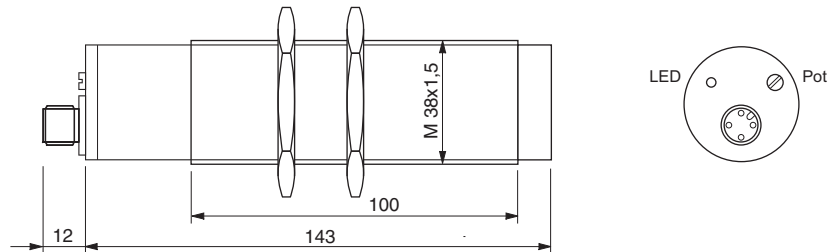

Sensing range [°C]	50...150	0...300
Output		
ID-No.	P61001	P61002
Type	OD 100 GA 150	OD 100 GA 300
Operating voltage [V]	18...32 DC	
Current consumption [mA]	<40	
Current output [mA]	4...20	
Field of view [°]	<10	
Reproduction [°C]	±1	
Temperature coefficient [%/K]	±0,1 of the measuring value	
Response time [ms]	<100	
Precision [%]	±3 of the measuring value	
Ambient temperature [°C]	-10...+60	
Load resistance R _L [Ω]	<500	
EMC-class	A	
Protection [EN 60529]	IP 67	
Housing material	AISI 316 Ti	
Connection	M12 connector	

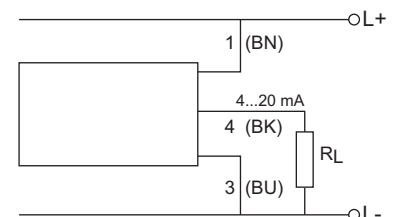
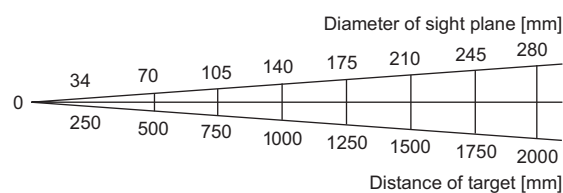
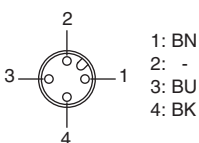

Accessories

see page 6.10

Fibre-optic amplifier

Series ODE

Contactless measurement of temperature

Measuring-range 300...2000 °C

Analog output 4...20 mA

Switching output PNP • Relay output

Threshold adjustable

Fibre-optic cable up to 350 °C

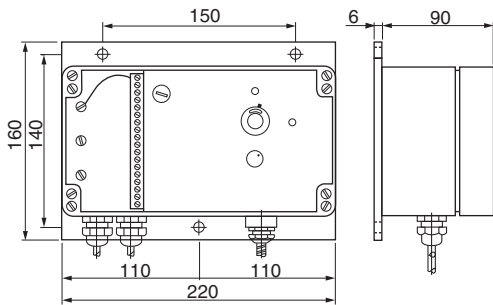

Design	ODE 350 GWR	
Dimensions		
Measuring range [°C]	300...2000	
Operating voltage [V]	230 AC, 24 DC	
ID-No.	P60031	
Type	ODE 350 GWR	
Power consumption [VA]	6	
Ambient temperature [°C]	-20...+70	
Relay output	AC	DC
Switching output max. [V]	440	250
Current max. [A]	8	8
Nominal switching power [VA]	2000 (AC-12)	240 (DC-12)
Voltage output [V]	0...10	
Load resistance [kΩ]	> 5	
Current output [mA]	4...20	
Load resistance [Ω]	< 470	
Current sensitivity [mA/V]	1.8	
EMC-class	A	
Protection [EN 60529]	IP 67	
Reponse time [ms]	< 100	

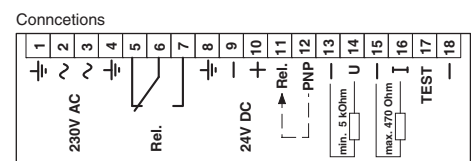
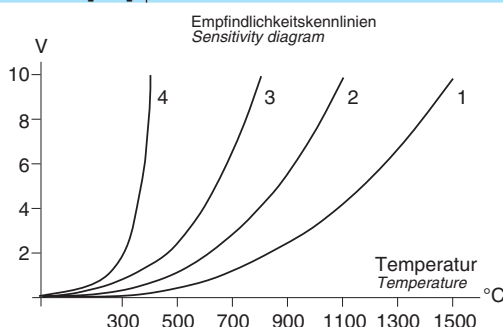

Rel. Relay output
PNP PNP output
I Current output
U Voltage output

switching threshold
switching threshold
20 mA ref. (-)
10 V ref. (-)

Note

Amplifiers with modified technical data on request

Optics and accessories

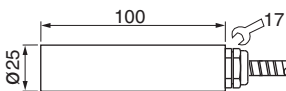
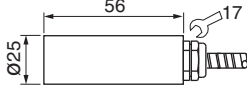
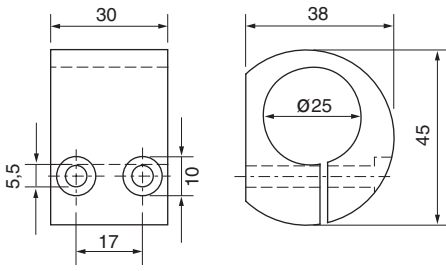
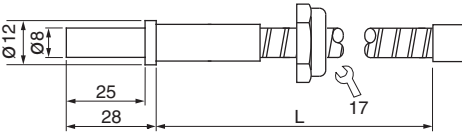
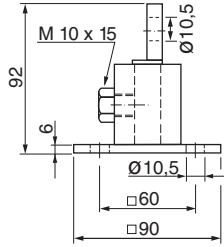
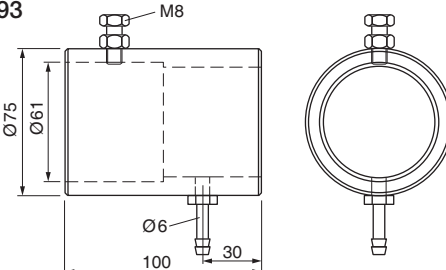
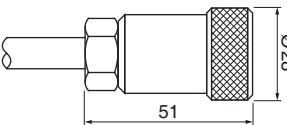
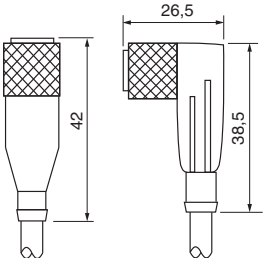
Type	ID-No.	Dimensions	Design
ULV 024	P60150		Front-optic View 4°
ULV 028	P60151		Front-optic View 8°
Mounting clamp Ø25	Z00126		Fixing device for front-optics ULV
LLKS-100-BE LLKS-200-BE LLKS-30-BE LLKS-500-BE LLKS-1000-BE	P60101 P60102 P60103 P60104 S60001		1 m fibre-optic cable up to 250 °C 2 m fibre-optic cable up to 250 °C 3 m fibre-optic cable up to 250 °C 5 m fibre-optic cable up to 250 °C 10 m fibre-optic cable up to 250 °C Fibre-optic cable with increased lengths or with protection hose on request.
OMB 01	Z06004		Rotating mounting
ODMV-D60	Z01193		Air curtain device for Series ODMO... with housing Ø 60 mm
VEG 5-5	Z00501		Connection plug cable ODM Connection plug cable with PU-cable 5 m IP 68
SLG 4-2 SLW 4-2	Z00445 Z00446		M12 connector Cable plug housing with 2 m cable

A selection

Flow sensors

- Electronical monitoring of flow
- Lubrication monitoring
- Measuring range 1 ml/min...100 l/min
- Detection range 1...300 cm/s
- Reaction time 0.5 s

Level sensors for Ex-applications

- For level monitoring in Ex areas
- For temperatures $-35...+200\text{ }^{\circ}\text{C}$
- With PTFE connector cable
- Sensors for connection to amplifiers

Level sensors

- For level monitoring $-230...+230\text{ }^{\circ}\text{C}$
- Steam proof at a pressure of up to 30 bar
- For hot motor oil
- For liquid nitrogen
- For chemically aggressive media

Ultrasonic sensors

- Switching distance up to 5000 mm
- Level monitoring
- Watertight housing
- Teach-in functions

Pressure sensors

- Compact model with digital display
- Monitoring in pipes and containers
- Pressure up to 16 bar
- Level up to 10 m ($\pm 1\text{ cm}$)
- Programmable

Temperature sensors

- Compact model with digital display
- Monitoring in pipes and containers
- Temperature $-40...+120\text{ }^{\circ}\text{C}$ ($\pm 0,3\text{ }^{\circ}\text{C}$)
- Pressure up to 100 bar
- Multi use output NO/NC + analog



Архангельск (8182)63-90-72	Калининград (4012)72-03-81	Нижний Новгород (831)429-08-12	Смоленск (4812)29-41-54
Астана +7(7172)727-132	Калуга (4842)92-23-67	Новокузнецк (3843)20-46-81	Сочи (862)225-72-31
Белгород (4722)40-23-64	Кемерово (3842)65-04-62	Новосибирск (383)227-86-73	Ставрополь (8652)20-65-13
Брянск (4832)59-03-52	Киров (8332)68-02-04	Орел (4862)44-53-42	Тверь (4822)63-31-35
Владивосток (423)249-28-31	Краснодар (861)203-40-90	Оренбург (3532)37-68-04	Томск (3822)98-41-53
Волгоград (844)278-03-48	Красноярск (391)204-63-61	Пенза (8412)22-31-16	Тула (4872)74-02-29
Вологда (8172)26-41-59	Курск (4712)77-13-04	Пермь (342)205-81-47	Тюмень (3452)66-21-18
Воронеж (473)204-51-73	Липецк (4742)52-20-81	Ростов-на-Дону (863)308-18-15	Ульяновск (8422)24-23-59
Екатеринбург (343)384-55-89	Магнитогорск (3519)55-03-13	Рязань (4912)46-61-64	Уфа (347)229-48-12
Иваново (4932)77-34-06	Москва (495)268-04-70	Самара (846)206-03-16	Челябинск (351)202-03-61
Ижевск (3412)26-03-58	Мурманск (8152)59-64-93	Санкт-Петербург (812)309-46-40	Череповец (8202)49-02-64
Казань (843)206-01-48	Набережные Челны (8552)20-53-41	Саратов (845)249-38-78	Ярославль (4852)69-52-93